

FLOOR MOUNTING HARDWARE FOR OVERHEAD SUPPORTED RACK

Modified:09/22/2009

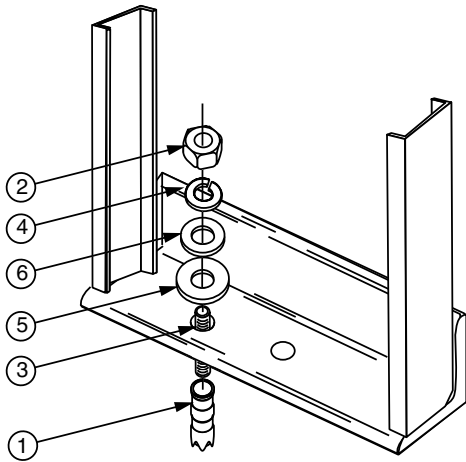

Part Number	
Ordering	0040180010

Stock List		
Item	Qty	Description
1	2	expansion shield
2	2	3/8"-16 nut
3	2	2-1/2" stud
4	2	3/8" lock washer
5	2	5/8" flat washer
6	2	3/8" flat washer

FLOOR MOUNTING HARDWARE FOR FLOOR SUPPORTED RACK

Sales Sheet Modified:01/23/2017

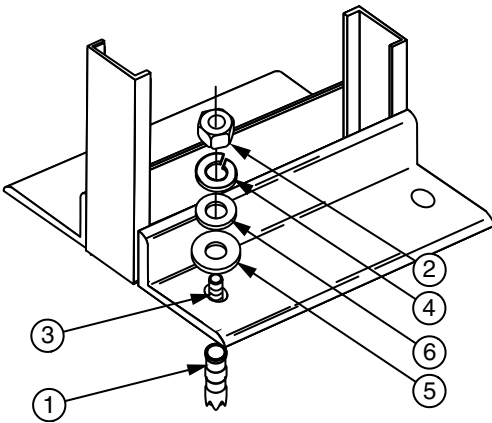

Ordering Table

Part Number	Qty	Hardware
0040190010	1	3/8
0040190110	1	5/8

C9

0040190010 Stock List

Item	QTY	Description
1	4	Expansion Shield
2	4	3/8"-16 Nut
3	4	2-1/2" Stud
4	4	3/8" Lock Washer
5	4	5/8" Flat Washer
6	4	3/8" Flat Washer

0040190110 Stock List

Item	QTY	Description
1	4	5/8" expansion shield
2	4	5/8" hhn
3	4	5/8" -11 x 3" threaded rod
4	4	5/8" lock washer
5	4	5/8" plain washer

FLOOR MOUNTING HARDWARE FOR OVERHEAD SUPPORTED RACK

Modified:09/22/2009

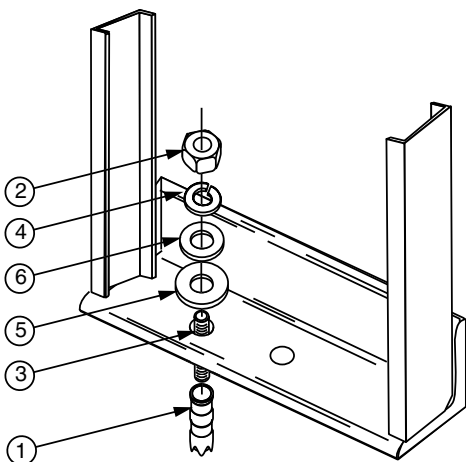

Part Number	
Ordering	0040180010

Stock List		
Item	Qty	Description
1	2	expansion shield
2	2	3/8"-16 nut
3	2	2-1/2" stud
4	2	3/8" lock washer
5	2	5/8" flat washer
6	2	3/8" flat washer

FLOOR MOUNTING KIT, SEISMIC

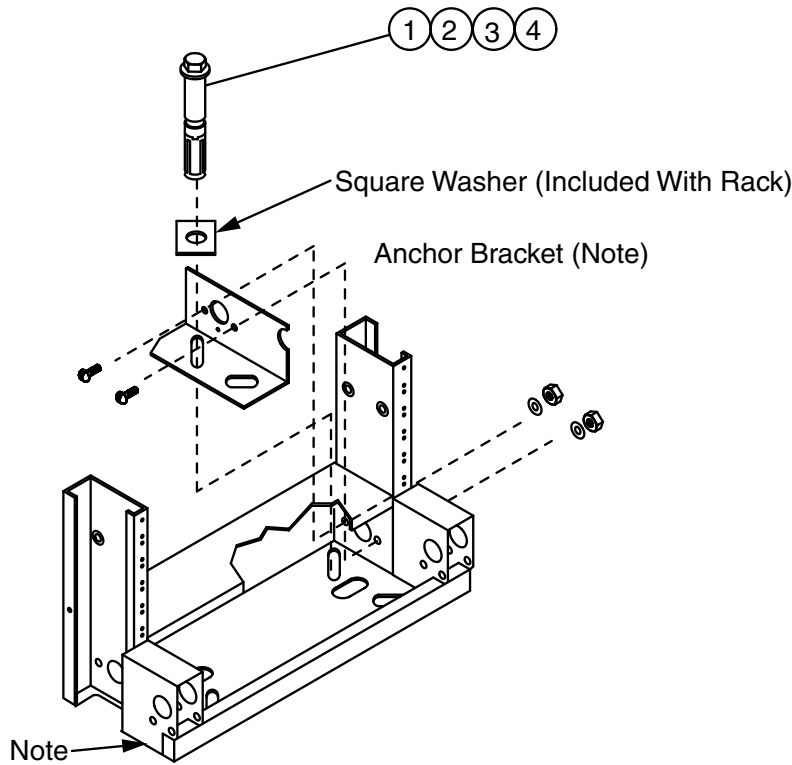

	Figure #	NEBs Approved Anchor	Qty
Ordering	2221280111	M12-50	4
	2221280211	M12-25	4

	Figure #	HILTI Anchor	Qty
Ordering	0046150110	HSLB M12-50	4
	0046150210	HSLB M12-25	4

Notes:

- Base configuration shown is for a representative seismic unequal flange equipment rack; other rack bases may be different.
- Anchor brackets are bolted in place in fig. 0046xx and fig. 0047xx series racks prior to shipment. 2" Square flat washer (quantity 4) provided with fig. 0046xx and fig. 0047xx series racks.

C9

A. Application

1. Used to secure seismic-rated equipment racks (or equivalent) to a concrete floor in a seismically active location (including Zone 4).
2. For use with all seismically rated equipment racks, four post frames or cabinets

B. Tools (required or recommended):

1. Hammer (or rotary) drill (with depth gauge recommended)
2. 18 Mm masonry drill bit.
3. Blowout air bulb or vacuum with small diameter tube.
4. 19 Mm socket (or equivalent) for hsl version; 24 mm socket (or equivalent) for

C. Installation procedure

1. Using the rack base, or equivalent, as a template, mark the four (4) hole locations to be drilled. Holes should be as far apart as possible within each cutout (refer to the floor mounting details for the rack being installed).
2. Using an 18 mm masonry bit, drill the four required holes to a minimum depth of 100 mm (appx. 4").
3. Verify that the anchor's minimum embedment depth (80 mm/3"), as marked by a ring on the sleeve of the anchor, can be met.
4. Thoroughly clean the dust from each hole, using an air blowout or vacuum device.
5. To not degrade the anchor's installed performance, any unused anchor holes (or

other nearby holes) within 3" must be filled with an epoxy filler (pour stone) or equivalent. Filled holes must be fully cured before anchors are installed and torqued.

6. If not already in place, install the anchor brackets inside the rack base. Secure the anchor brackets (left hand and right hand respectively) to the rack's uprights using two (2) grade 5 or better 1/2"-13 x 1-1/2" cap screws, lock washers and hex nuts in each anchor bracket. Tighten each bolt to 65 ft-lbs, +10, -0 ft-lbs.
7. Place the rack over the predrilled holes and align as necessary.
8. Slide one 2" square washer onto the anchor being used. Ensure that the anchor's expansion shield is not expanded. Place the end of the anchor into the predrilled hole. Repeat for the other predrilled holes.
9. Align the edges of the 2" square washer parallel with the slots in the rack base to obtain the maximum material overlap. Once aligned, tap each anchor/washer assembly until it is seated in the hole and firmly against the 2" square washer.
10. Pre-tighten each anchor with a socket wrench or box-end wrench; do not use an open-end wrench (which could easily slip off and cause injury). Before final tightening, ensure that the rack is properly aligned (in the row and with any adjacent racks).
11. Torque each anchor to 60 ft-lbs. When using the break off type anchor, a torque wrench is

not required since the anchor's (red) torque cap shears off at a predetermined torque value (appx. 60 Ft-lbs.), Leaving a green seal on the bolt head, indicating proper tightening.

D. Caution

1. Anchor brackets must be properly installed (bolted to the rack upright with bolts properly torqued to 65 ft-lbs, +10, -0 ft-lbs) and the rack must be properly secured to the concrete floor using the appropriate seismic floor mounting kit. Installing the rack in any other manner may reduce the load and/or seismic performance of the installation. Junctioning to adjacent racks (using fig. 004619 Or equivalent), securing the rack to overhead structure, etc. may also be added, but these do not replace proper installation of the seismic floor mounting kit.

FLOOR MOUNTING HARDWARE WITH EXPANSION SHIELD

Modified:09/22/2009

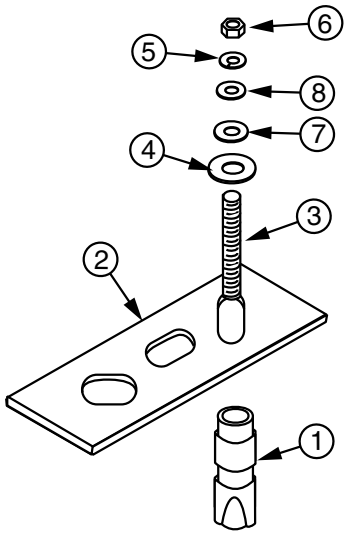

Part Number	
Ordering	0041100010

Stock List		
Item	Qty	Description
1	4	3/8" x 1-1/2" expansion shield
2	2	hold down bar
3	4	stud 3/8"-16 thread
4	4	5/8" flat washer
5	4	3/8" lock washer
6	4	3/8"-16 lock washer
7	4	1/2" flat washer
8	4	3/8" flat washer

C9

NETBAY FLOOR ANCHOR KIT

Modified:09/22/2009

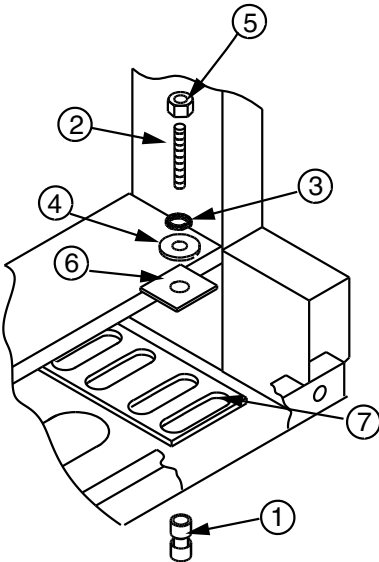

Ordering Table		
part number	qty	
0044220010	1	
0044220110	1	

0044220010 Stock List		
Item	Qty	Description
1	4	1/2" HILTI drop in anchor
2	4	1/2-13 x 3-1/4" stud
3	4	1/2" lockwasher
4	4	1/2" flat washer
5	4	1/2-13 hex nut
6	4	2" square washer
7	2	hold down plate

0044220110 Stock List		
Item	Qty	Description
1	4	1/2" HILTI drop in anchor
2	4	1/2-13 x 3-1/4" stud
3	4	1/2" lockwasher
4	4	1/2" flat washer
5	4	1/2-13 hex nut
6	4	2" square washer

ATTACH A RACK TO CONCRETE BELOW RAISED FLOOR

Modified:08/30/2012

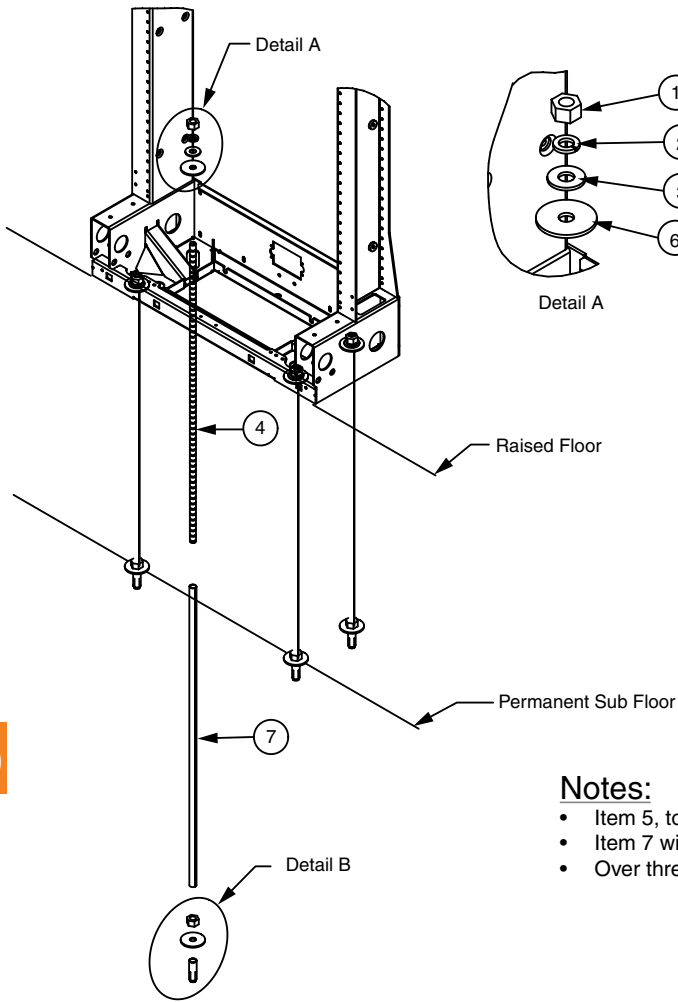

part number	
Ordering Table	22033600xx

Stock List		
Item	Qty	Description
1	8	1/2-13 Hex Nut
2	4	1/2 Lock Washer
3	4	1/2 Flat Washer
4	4	1/2-13 X 30 Threaded Rod
5	4	Hilti Hdi 1/2" Anchor
6	8	1/4 X 2" Dia Flatwasher, .515 Hole
7	4	Split Tubing 30"

Notes:

- Item 5, to be installed using a 5/8" drill bit, with a minimum embedment depth of 2".
- Item 7 will need to be trimmed to fit final assembled height. Split tubing can be slipped over threaded rod after assembly.

C9

LEVELING SHIM KIT

Modified:02/08/2012

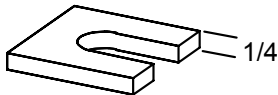

only available in steel

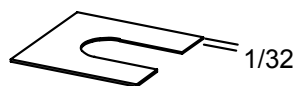
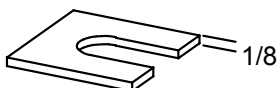
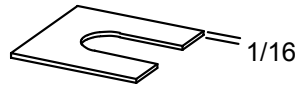

Ordering Table							
Part Number	Shim(s)	1/4"	1/8"	1/16"	1/32"	material	
2147610100	2" x 2"		12	12	12	Phenolic	
2136040010	2.5" x 2.5"		2	2	4	Steel	
2136040110	2.5" x 2.5"	2	2	4	2	Steel	

HOLD DOWN KIT

Modified:05/21/2012

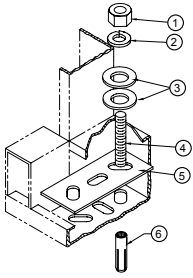

Ordering Number : 2100761110

Item	Qty	Description
1	4	5/8"-11 x 1-1/16" hhn
2	4	5/8" spring lock washer
3	8	5/8" flat washer
4	4	5/8" stud
5	2	hold down plate
6	4	anchor, drop in, HDI 5/8"

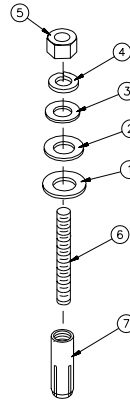

Ordering Number : 2100760110

Item	Qty	Description
1	4	5/8" flat washer
2	4	1/2" flat washer
3	8	3/8" flat washer
4	4	3/8" lock washer
5	4	3/8" hex nut
6	4	4" x 3/8" stud
7	4	drop in anchor HDI 3/8"

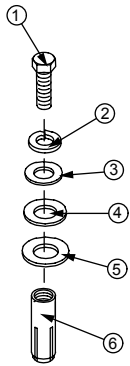

Ordering Number : 2100760610

Item	Qty	Description
1	1	3/8" -16 x 7/8" hhcs
2	1	3/8" lock washer
3	1	3/8" flat washer
4	1	1/2" lock washer
5	1	5/8" flat washer
6	1	anchor, drop in, HDI 3/8"

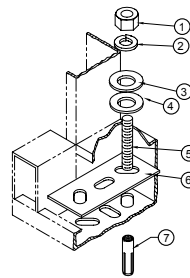

Ordering Number : 2100761010

Item	Qty	Description
1	4	1/2"-13 x 7/8" hhn
2	4	1/2" spring lock washer
3	4	1/2" flat washer
4	4	5/8" flat washer
5	4	1/2" stud
6	2	hold down plate
7	4	anchor, drop in, HDI 1/2"

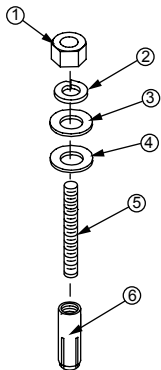

Ordering Number : 2100760710

Item	Qty	Description
1	4	1/2" hex nut
2	4	1/2" lock washer
3	4	1/2" flat washer
4	4	5/8" flat washer
5	4	1/2"-13 x 3-1/4" stud
6	4	anchor, drop in, HDI 1/2"

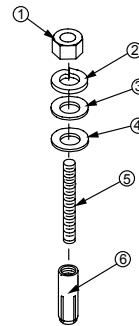

Ordering Number : 2100760910

Item	Qty	Description
1	2	1/2" hex nut
2	2	1/2" lock washer
3	2	1/2" flat washer
4	2	5/8" flat washer
5	2	1/2"-13 x 3-1/4" stud
6	2	anchor, drop in, HDI 1/2"

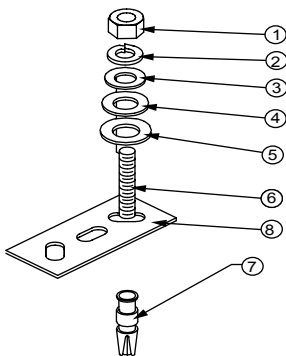

Ordering Number : 2100760810

Item	Qty	Description
1	4	3/8" hex nut
2	4	3/8" lock washer
3	4	3/8" flat washer
4	4	1/2" flat washer
5	4	5/8" extra heavy flat washer
6	4	3/8"-16 x 4" stud
7	4	anchor, drop in, HDI 3/8"
8	2	hold down plate

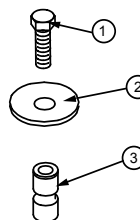

Ordering Number : 2100760510

Item	Qty	Description
1	1	3/8"-16 x 1" hhcc
2	1	3/8" x 2" OD washer
3	1	drop-in anchor, HDI 3/8"

CASTER BASE FOR FREESTANDING CHANNEL TYPE EQUIPMENT RACK

Modified:05/19/2010

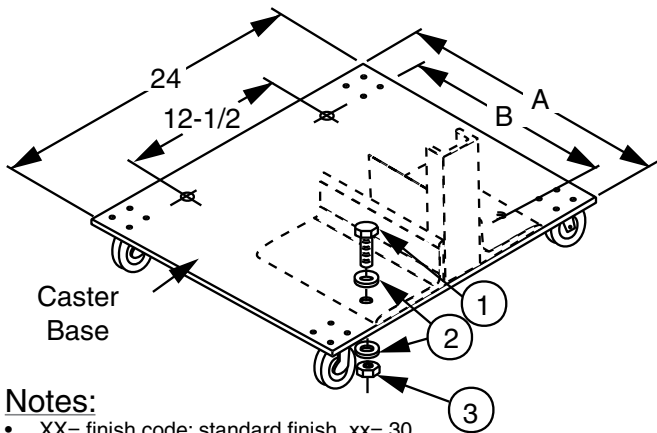

Notes:

- XX= finish code; standard finish, xx= 30.
- Material is 1/4" thick hrs.
- Base is preassembled.
- Caster base load rated at 800 lbs.
- Four swivel casters.

	part number	rack size	A	B
Ordering Table	00408101xx	19"	21"	16"
	00408102xx	23"	25"	20"

	Item	Qty	Description
Stock List	1	4	1/2"-13 x 1-1/2" hhcs
	2	8	1/2" flat washer
	3	4	1/2"-13 hex nut

RACK DOLLY SET - UFER

Modified:10/15/2009

C9

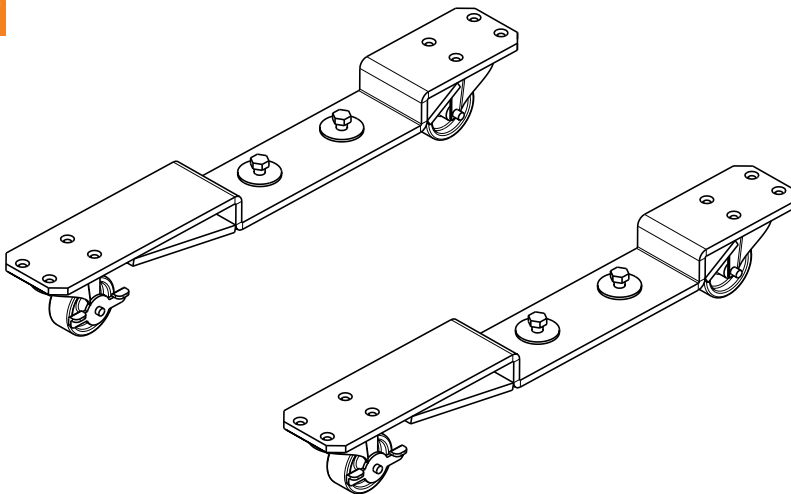

	part number
Ordering Table	21917400xx

Notes:

- Each dolly is rated for 500 lbs.
- A set of dollies will support a rack weight of 1000.

