

NEWTON SERVER FRAME (NSF84)

Modified:02/03/2011

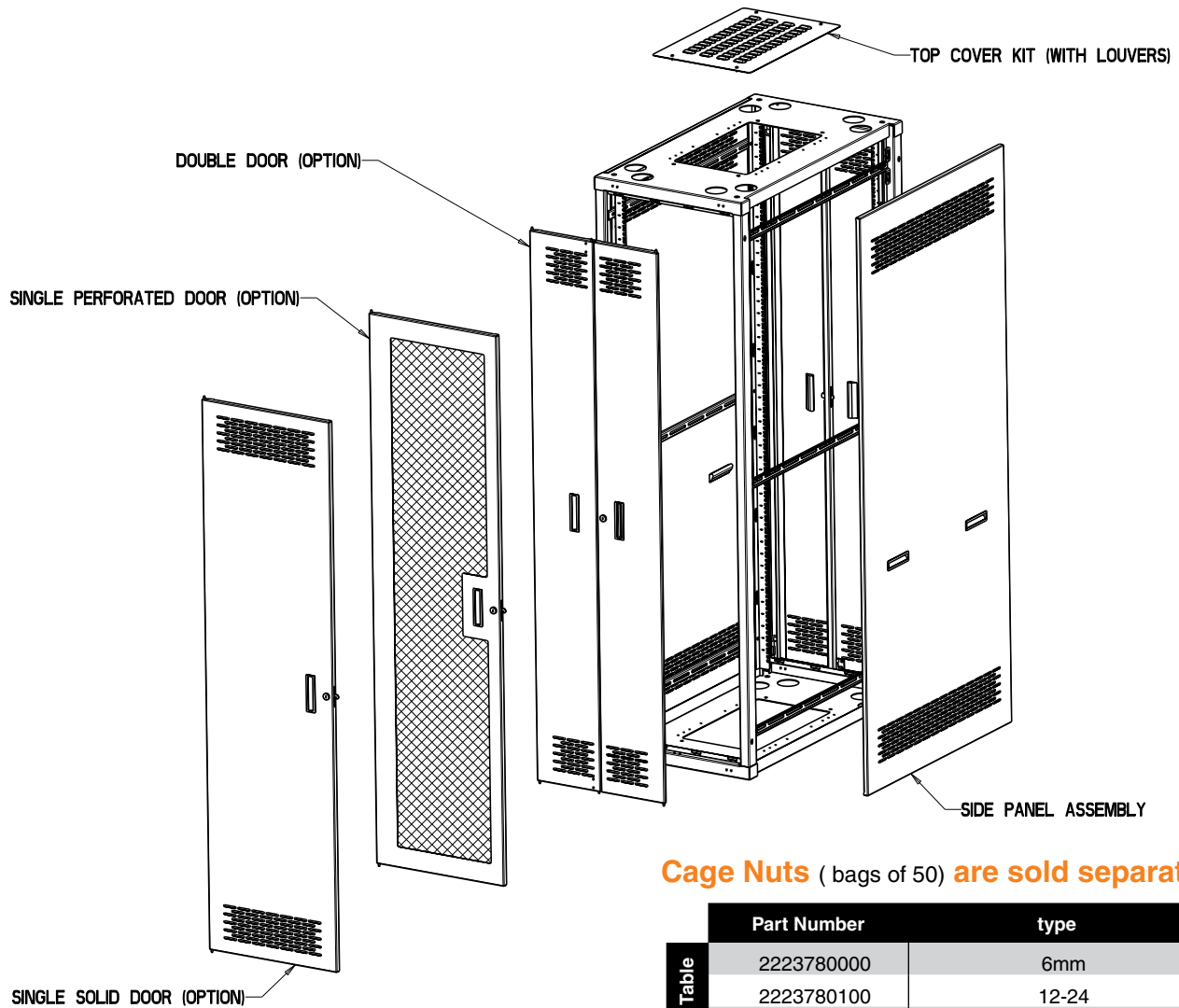

Cage Nuts (bags of 50) are sold separately.

	Part Number	type
Ordering Table	2223780000	6mm
	2223780100	12-24
	2223780200	10-32

NSF84 + AA + B + C + D + 47

D4

NSF84	AA	B	C	D	47
<p>NSF84: (7'-0" height)</p> <p>AA = DEPTH OF CABINET 24 = 24" deep 30 = 30" deep 36 = 36" deep 42 = 42" deep</p> <p>B = FAN OPTION. 0 = No fan, no cover 1 = no fan + cover 2 = 4 x 5" AC fans</p>				<p>D = SIDES 0 = No sides 1 = 2 x solid side covers (small air slots bottom and top)</p> <p>C = DOOR OPTIONS 0 = No doors 1 = 2 x Single solid doors (small air slots bottom and top) 2 = 2 x Single perforated doors 3 = 2 x Double door assemblies (solid)</p>	<p>XX: FINISH CODE 47 = BLack</p>

SHELF, VENTED, 4-POINT MOUNTING

Modified: 10/07/2009

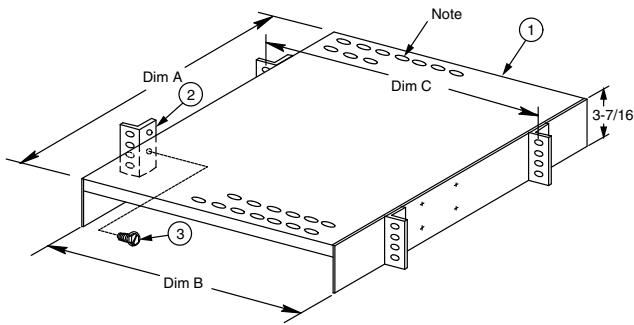

Notes:

- Xx = finish code; standard finish, xx= 30.
- Vent holes shown are representative of entire shelf hole pattern.
- Mounting ears are adjustable on 1" centers.

	Part Number	A	B	C
Ordering	21185501xx	24"	16-35/64"	18-15/16"
	21185502xx	24"	20-35/64"	22-15/16"
	21185503xx	16"	16-35/64"	18-15/16"
	21185504xx	22-1/2"	16-35/64"	18-15/16"
	21185505xx	24"	25-19/64"	27-15/16"
	21185506xx	21"	16-35/64"	18-15/16"

	Item	Qty	Description
Stock List	1	1	shelf
	2	4	bracket
	3	16	12-24 x 3/8 shhms

VENTED SHELF, FIXED

Modified: 12/28/2009

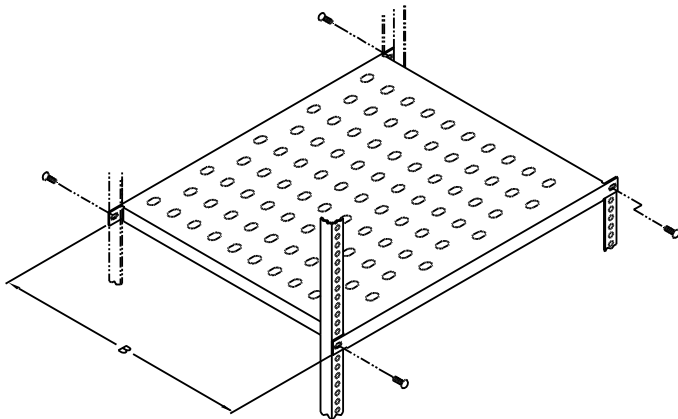

	Part Number	A	B
Ordering Table	21391801xx	19"	15"
	21391802xx	23"	15"
	21391803xx	19"	22"
	21391804xx	23"	22"

ADJUSTABLE SHELF KIT FOR SERVER FRAME

Modified: 11/23/2010

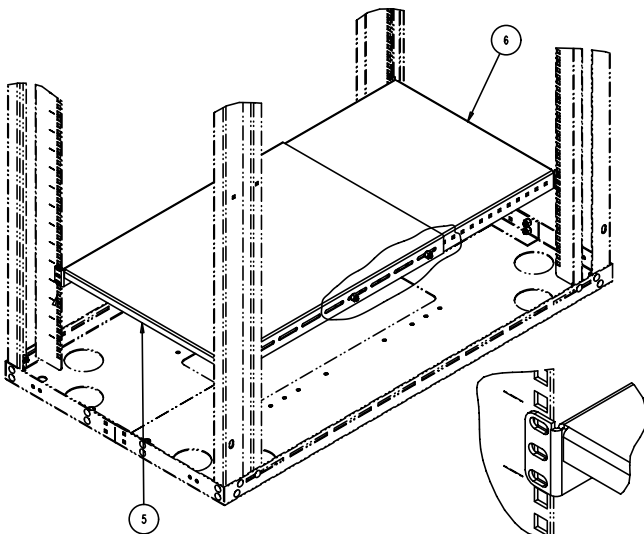

Note:

- Approximately 17-1/2" wide

	Part Number	Adjustable	Rack Size
Ordering	22242401xx	24"-38"	19"
	22242402xx	18"-28"	19"

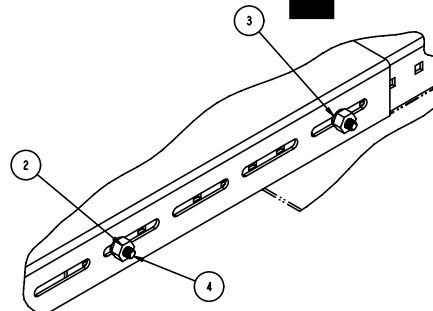

D4

SERVER FRAME SHELF

Modified: 10/06/2009

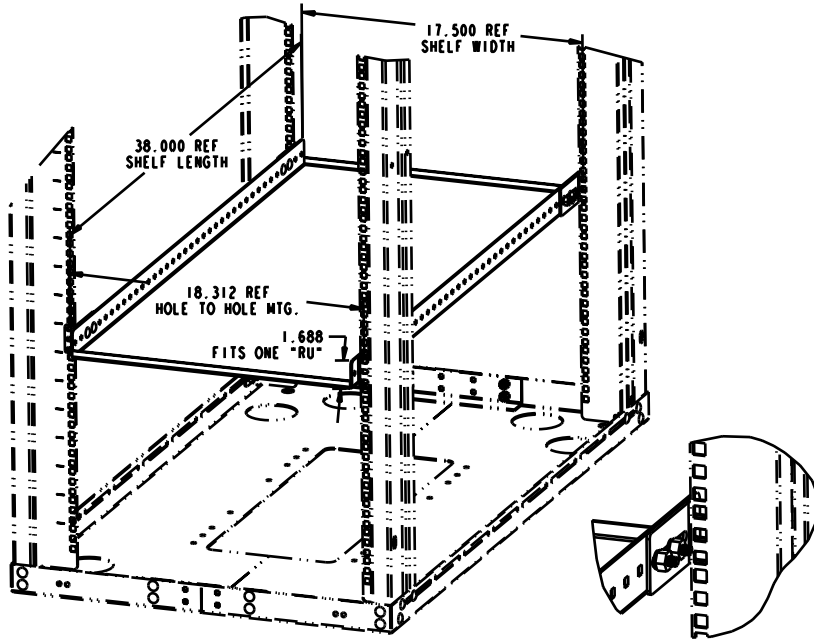

	Part Number	Width
Ordering Table	22235401xx	19"

Notes:

- Solid shelf
- 17-1/2" wide x 38" deep
- Cage nuts not included
- Mounting ears are adjustable on 1" centers

SERVER FRAME SHELF, VENTED

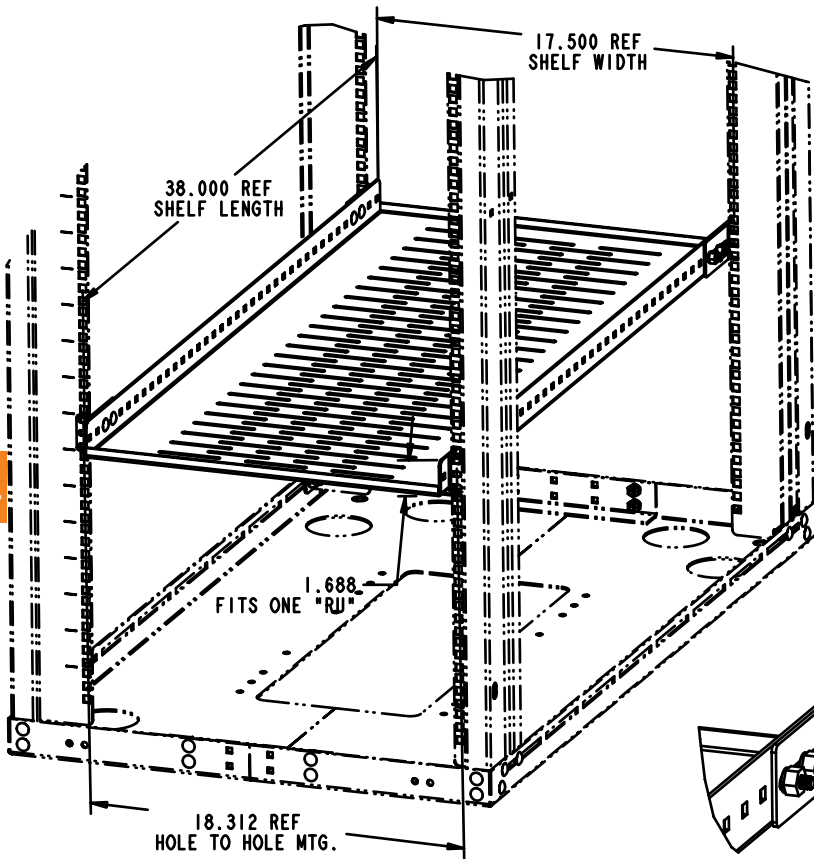

	Part Number	Width
Ordering Table	22235402xx	19"

Notes:

- Vented shelf
- 17-1/2" wide x 38" deep
- Cage nuts not included
- Mounting ears are adjustable on 1" centers

D4

UNIVERSAL/CARD STORAGE CABINET, 72" HEIGHT

Modified:11/04/2009

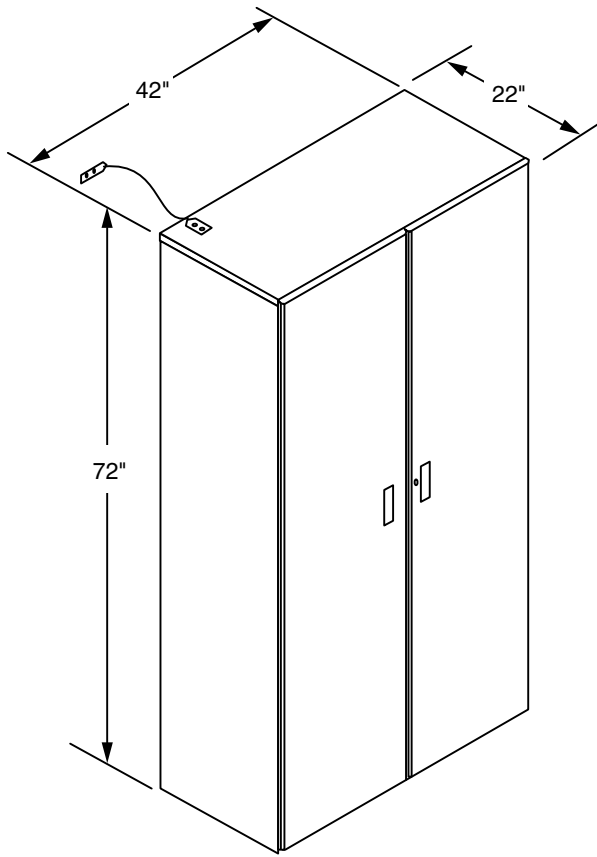

	Part Number	assembly
Ordering	00600200xx	welded
	00600250xx	riveted

Notes:

- PATENT NO. 5,008,779
- Xx= finish code; standard finish, xx=73 (beige). Other colors available upon request.
- Cabinet includes 8 adjustable shelves (fig. 006005) And two fixed shelves, creating eight storage spaces (refer to fig. 006000).
- Refer to accessories for additional shelves.
- Cabinet includes door lock.
- Cabinet is equipped with levelers on all four corners.
- Floor anchored (for hardware, refer to accessories).
- Each card shelf has 27 slots spaced on 5/8" centers and accepts cards up to 20" deep.
- Card guides contain electrostatic dissipative properties.
- Both dash numbers are **form, fit and functionally** identical. The riveted version is a *cost effective alternative*.

GENERAL INFORMATION; ADJUSTING UNIVERSAL SHELF

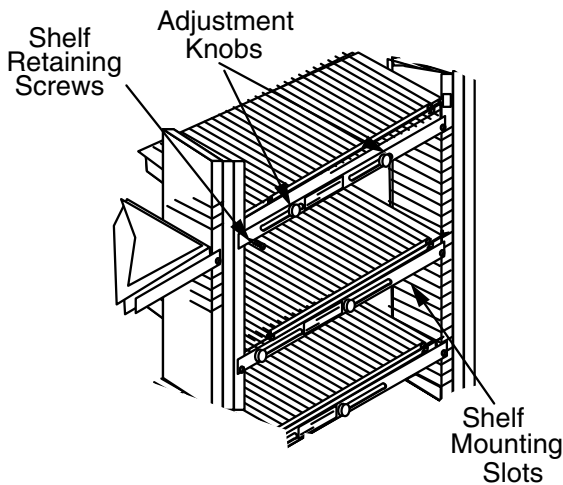

Notes:

- PATENT NO. 5,008,779
- Universal Shelf Fits All Newton Universal Card/Storage Cabinets.
- Shelf Mounting Slots Are 3/4" Apart. Shelf Slides Into Slot And Is Held In Place With Two 8-32 Self-Tapping Screws. From This Fixed Position, Top Of Shelf With Card Guides Will Move 3/4" Upward By Sliding Knobs To The Right. With Slots 3/4" Apart And 3/4" Fine Adjustment, This Cabinet Will Accept Cards Of All Heights.
- Each Card Shelf Has 27 Slots Spaced On 5/8" Centers And Accepts Cards Up To 20" Deep.

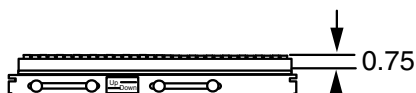

D4

UNIVERSAL CARD/STORAGE CABINET, 42" HEIGHT

Modified:09/22/2009

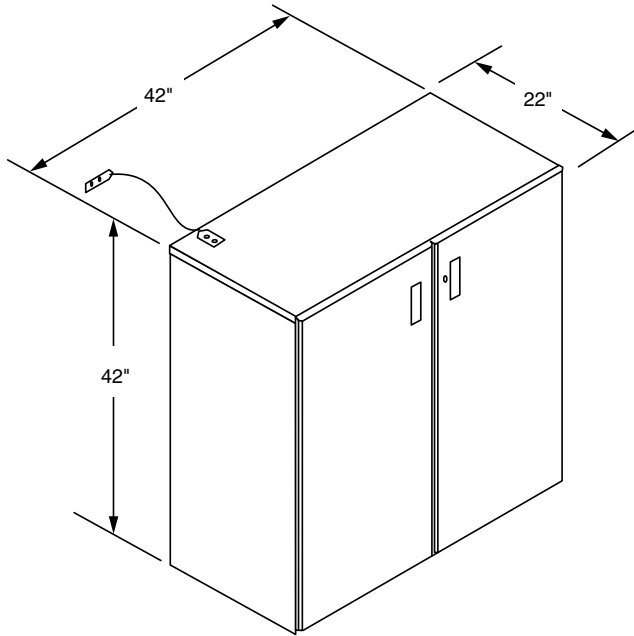

Ordering	Part Number
	00600300xx

Notes:

- PATENT NO. 5,008,779
- Xx= finish code; standard finish, xx=73 (beige). Other colors available upon request.
- Cabinet includes six adjustable shelves (fig. 006005) And two fixed shelves, creating 6 adjustable storage spaces. (Refer to fig. 006000).
- Refer to accessories for additional shelves.
- Cabinet includes door lock.
- Cabinet is equipped with levelers on all four corners.
- Floor anchored (for hardware, refer to accessories).
- Each card shelf has 27 slots spaced on 5/8" centers and accepts cards up to 20" deep.
- Card guides contain electrostatic dissipative properties.

CABINET, 26" H X 28" W X 15" D

Modified:01/23/2017

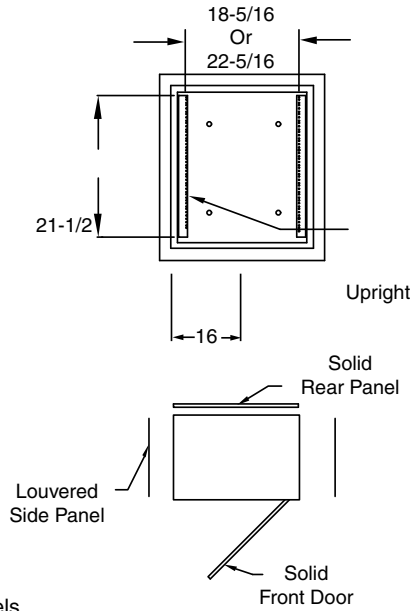
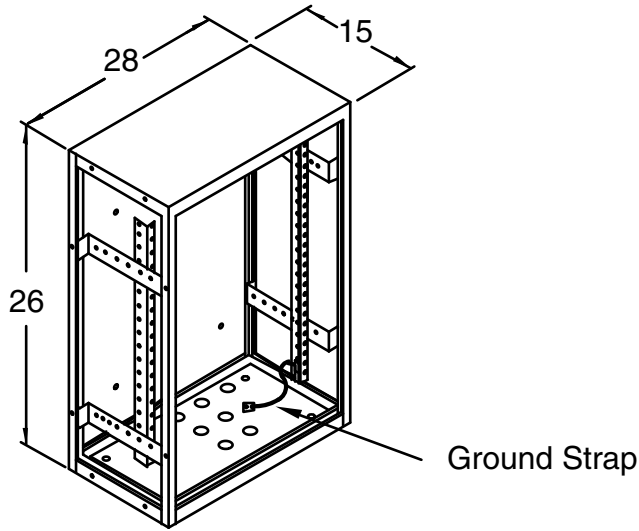

Ordering	part number
	21503900xx

Notes:

- Xx = finish code; standard finish, xx= 30.
- Includes solid front door, solid rear panel, and two louvered side panels.
- Reversible uprights for 19" or 23" equipment mounting.
- Floor or wall mountable. Mounting hardware not included.

STABILIZING BRACKET INSULATION KIT FOR HALF AND FULL HEIGHT CABINET

Modified:09/22/2009

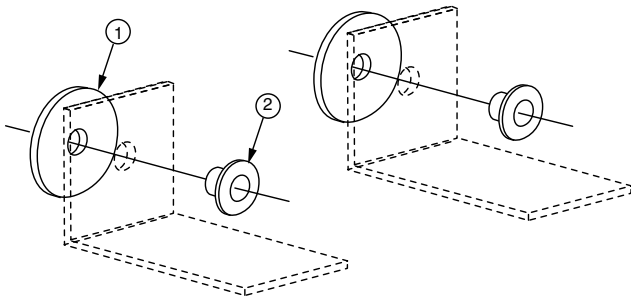

Stock List			Ordering	
Item	Qty	Description	part number	
1	2	insulator washer	0060180000	
2	2	insulator bushing		

Notes:

- Insulator material is rated ul 94 v-1 and has an oxygen index rating of greater than 29.

LEVELING FEET KIT

Modified:10/08/2009



Ordering		Part Number	Qty
		2200660000	4

ADJUSTABLE SHELF

Modified:09/22/2009

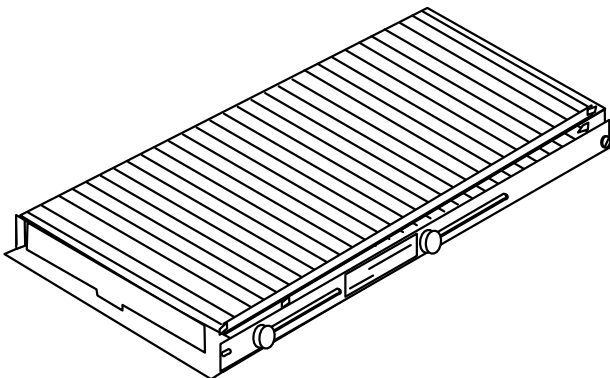

Ordering		Part Number	Stock List		
		0060050010	Item	Qty	Description
			1	1	shelf assembly
			2	2	8-32 x 1/2 sts

Notes:

- PATENT NO. 5,008,779
- Standard finish is zinc plated and gold chromate.
- Adjustable shelf fits all newton universal card/ storage cabinets.
- To mount in cabinet, slide into slots along sides of cabinet. Self-tapping screws hold shelf in place. (Refer to 006000).
- Shelf will adjust up to 3/4" by moving knobs in slots (to the right - up, to the left - down); refer to 006000.

FLAT SURFACE SHELF

Modified:09/22/2009

D4

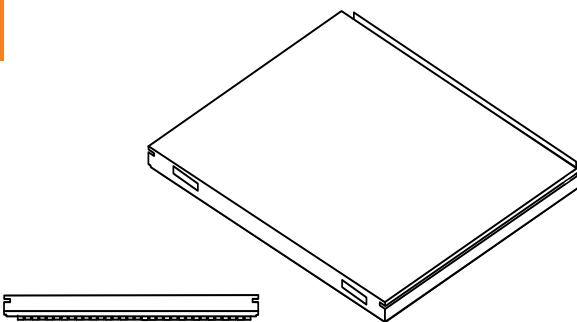

Ordering		Part Number	Stock List		
		0060060010	Item	Qty	Description
			1	1	shelf assembly
			2	2	8-32 x 1/2 sts

Notes:

- Standard finish is zinc plated and gold chromate.
- When flat storage is needed, order this shelf. Shelf fits all newton universal card/storage Cabinets.
- Card guide slots are mounted on bottom of Shelf only.
- To mount in cabinet, slide into slots along sides of Cabinet. Self-tapping screws hold shelf in place.

MAGNETIC TAPE REEL STORAGE SHELF

Modified:10/16/2009

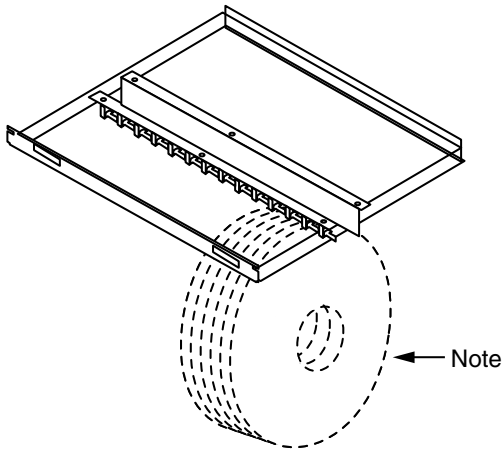

Part Number	
Ordering	0060070010

Item	Qty	Description
Stock List	1	1 shelf assembly
	2	2 8-32 x 1/2 sts

Notes:

- Standard finish is zinc plated and gold chromate.
- Holds up to 14 10-1/2" tape reels of all cartridge types. Shelf fits all newton universal card/storage Cabinets.
- To mount in cabinet, slide into slots along sides of Cabinet. Self-tapping screws hold shelf in place.
- Tape reels not included.

CARD RETAINER

Modified:09/22/2009

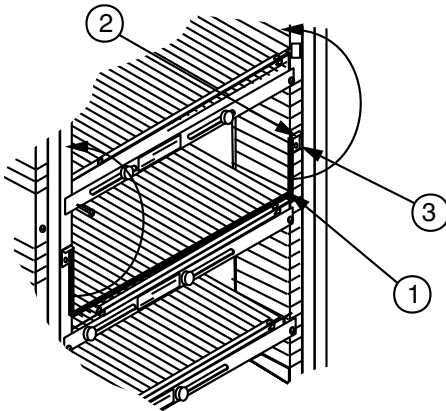

Part Number	
Ordering	0060090011

Item	Qty	Description
Stock List	1	2 wire clip
	2	2 8-32 x 1/2" sts
	3	1 wire car retainer

DRAWER ASSEMBLY

Modified:09/22/2009

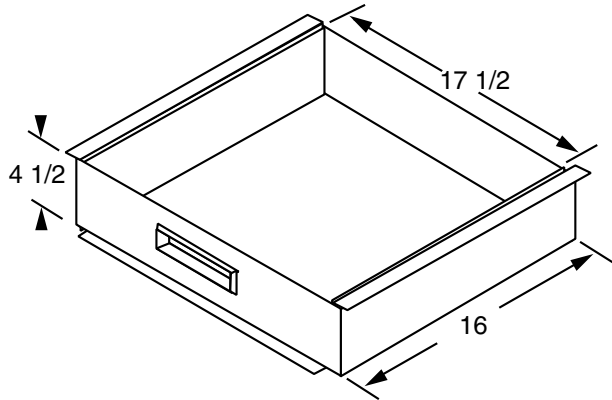

Part Number	
Ordering	00601000xx

Stock List			
Item	Qty	Description	
1	1	drawer assembly	
2	4	8-32 x 1/2" sts	

Notes:

- Xx= finish code; standard finish, xx= 73 (beige). Other colors available upon request.
- To mount in cabinet, slide into slots along sides of cabinet. Drawer fits all newton universal card/storage cabinets.
- Card guide slots are mounted on bottom of fixed drawer housing.
- Drawer slides have stops located at full open position.

DOCUMENT POCKET

Modified:10/15/2009

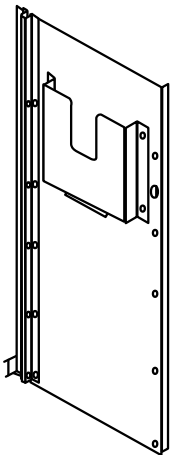

part number	
Ordering	00601100xx

Stock List			
Item	Qty	Description	
1	1	document pocket	
2	6	8-32 x 1/2 sts	

Notes:

- Xx= finish code; standard finish, xx=73 (beige).
- Document pocket is attached using sheet metal.
- Screws provided.
- Pocket is 9-1/2" w x 9" h x 1" d.

FLOOR ANCHOR KIT

Modified:09/22/2009

D4

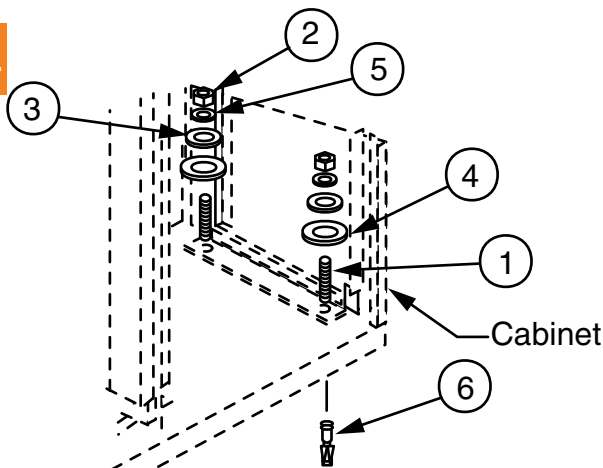

part number	
Ordering	0060120010

Stock List			
Item	Qty	Description	
1	4	3/8-16 x 6" threaded stud	
2	4	3/8-16 hhn	
3	4	3/8 flat washer	
4	4	1/2 plain washer	
5	4	3/8 lock washer	
6	4	3/8-16 expansion shield	

Notes:

- Standard finish is zinc plated and gold chromate.
- Levelers remain functional when anchor kit is used.

WALL MOUNTING KIT FOR RACK MOUNTED CABINET

Modified:09/22/2009

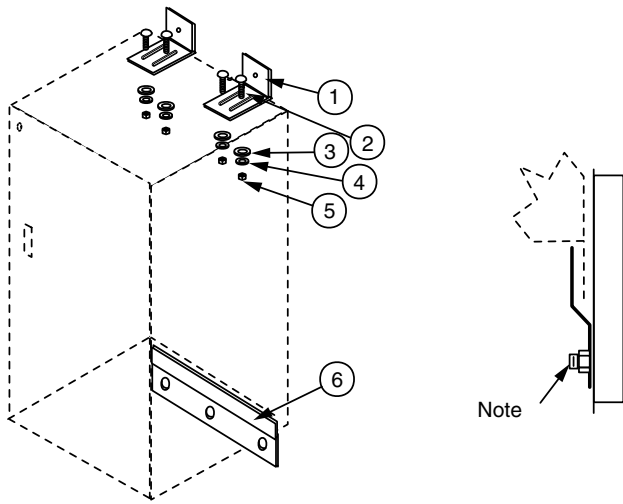

part number	
Ordering	00601300xx

Item	Qty	Description
1	2	wall anchor bracket
2	4	1/4-20 x 3/4 carriage bolt
3	4	1/4 x 20 flat washer
4	4	1/4-20 lock washer
5	4	1/4-20 hhn
6	1	wall mtg bracket

Notes:

- Xx= finish code; standard finish, xx= 73 (beige). Other colors available upon request.
- Wall attachment hardware is ordered separately (refer to section 3000).
- For insulation kit refer to 006017.

STABILIZING BRACKET FOR 36" OR 72" HEIGHT CABINET

Modified:04/02/2013

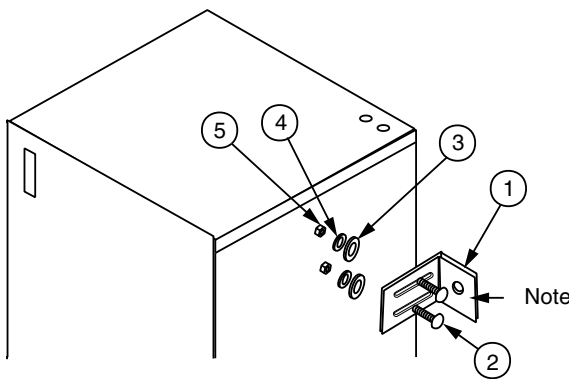

part number	
Ordering	00601400xx

Item	Qty	Description
1	2	wall anchor bracket
2	4	1/4"-20 x 3/4" carriage bolt
3	4	1/4"-20 flat washer
4	4	1/4"-20 lock washer
5	4	1/4"-20 hhn

Notes:

- Xx= finish code; standard finish, xx= 73 (beige). Other colors available on request.
- Wall attachment hardware is ordered separately.

FLOOR INSULATION KIT

Modified:09/22/2009

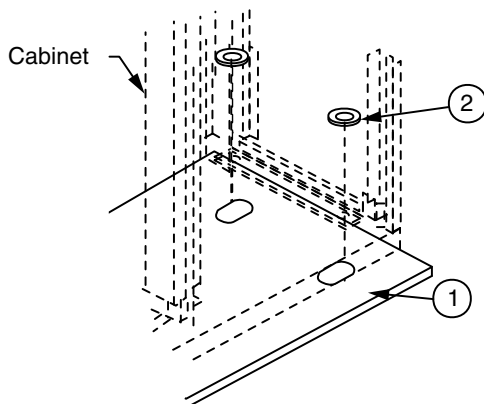

part number	
Ordering	0060150000

Item	Qty	Description
1	1	insulator pad
2	4	bushings

Notes:

- Insulator material is rated u.L. 94 V-1 and has an oxygen index of greater than 29.

D4

NOTES: