

# Universal Battery Shelf

Modified:05/05/2011

**NEWTON**<sup>®</sup>

INSTRUMENT COMPANY

111 East "A" Street  
Butner, NC 27509  
p (919) 575-6426  
f (919) 575-4708  
www.newton.com

## Introducing Newton's Universal Battery Shelf.

Designed to store and secure different styles of back up batteries in the communication environment, this versatile shelf can be used for any heavy loading application.

Engineered to hold up to four 150lb batteries, the Newton Universal Battery Shelf also includes two battery straps and a spacing kit to further secure the battery load.

Subtle design enhancements allow this shelf to be mounted to a data style rack with 3" wide uprights, an unequal flange rack with 5" wide uprights as well as two other rack configurations (for a heavier duty rack and a four post frame).

## FEATURES:

- Designed for a 23" rack with EIA wide mounting (1-1/4" - 1/2")
- Will accommodate batteries from 20" to 22" deep, spacers included with shelf.
- Battery holding straps can fit from a 7-7/8" high to 12-1/2" high battery.
- Shelf fits most types of 23" two post equipment racks and some 4 post frames.
- Available in Telco Gray (30 finish) and Satin Black (47 finish) as standard.
- Batteries can be changed without removing shelf
- Shelf corners are welded creating fully sealed tray.

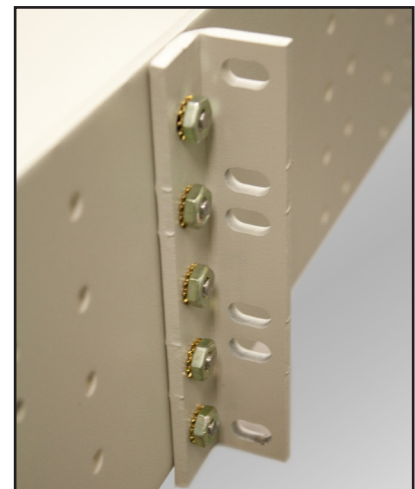
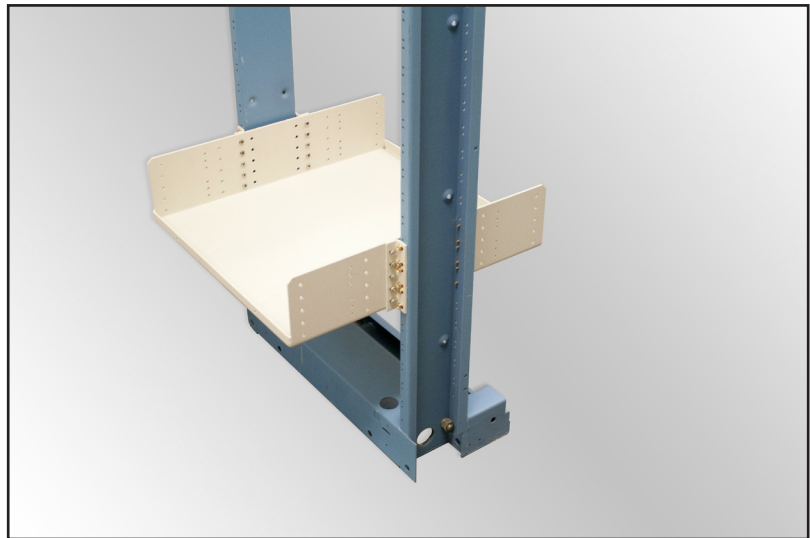

**UNIVERSAL BATTERY SHELF**

Modified:05/04/2011

	Part Number	Color
Ordering Table	2228660230	gray
	2228660247	black

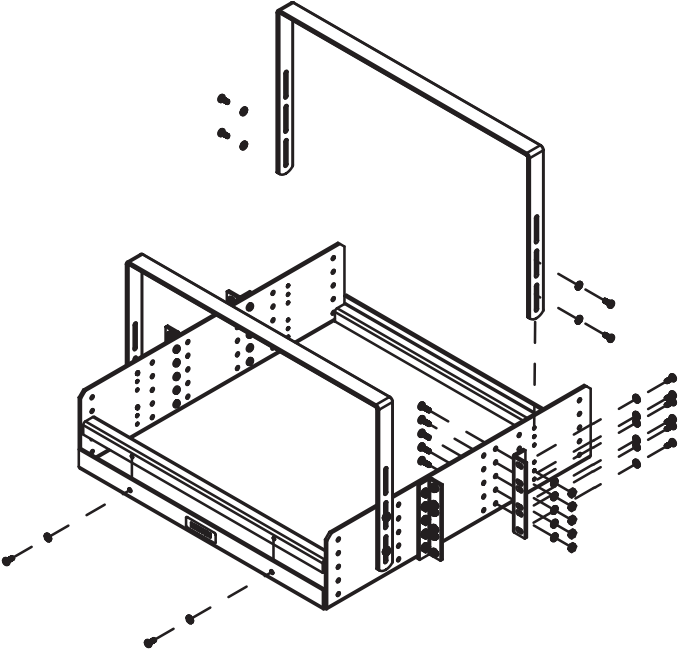
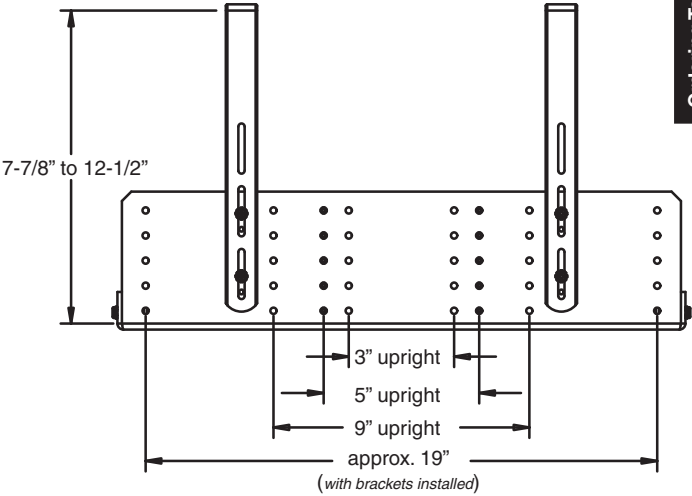
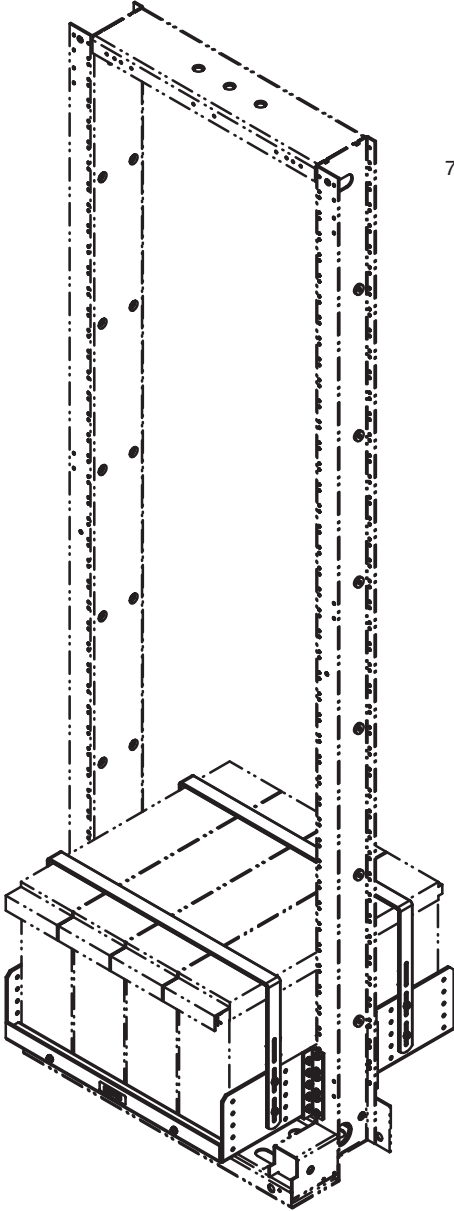

**Notes:**

- Outside dimensions approximately 21"W x 22.5"D x 5.5"H
- Maximum shelf capacity of 600 lbs.  
**\*\*To ensure maximum load rating, all provided mounting hardware must be used to install Battery Shelf into the rack. \*\***
- Batteries shown for illustration, not included with shelf.