

# NEWTON VERTICAL CABLE MANAGEMENT – *DOUBLE SIDED*

Customer Premise *Double-Sided Vertical Cabling Section*

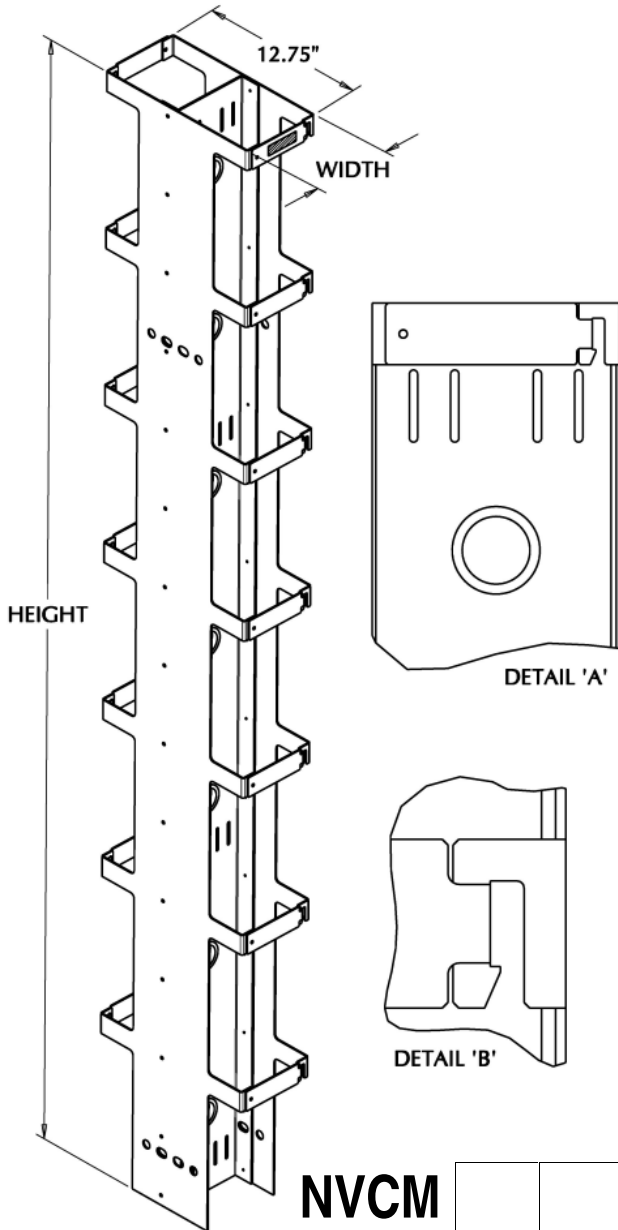

Newton Vertical Cable Management (NVCM) systems offer space-saving, high quality, and lightweight cable management options. They are double-sided, mount between equipment racks (both Newton's and others'), and all edges are protected against possible cable wear and abrasion. Available in narrow (3.65") and wide (6.00") widths, and various heights (see ordering chart below).

**Features:**

- Sturdy, lightweight aluminum construction
- Four sets of vertical slots for use with cable / zip ties for organized, bundled cables (see **Detail 'A'**)
- Seven cable and wiring pass-through holes (1 5/8" diameter) with edge protection (see **Detail 'A'**)
- Positive-locking rotating latches every 12" (see **Detail 'B'**)
- Plastic grommeting provided on all edges ensures cables and wires are protected (on unfinished units only)
- Approximate weight of 84" (7'-0") unit is 20 pounds
- Mounting hardware included with every unit
  - Additional mounting hardware available by ordering part number 2131720110
- Various heights, widths, and finishes available (see ordering chart below)

**NVCM**

**Height:**

084 = 84" / 7' overall height  
096 = 96" / 8' overall height

**Width:**

365 = outside width dimension of 3.65"  
600 = outside width dimension of 6.00"

**Finish:**

23 = Brushed Aluminum  
30 = Telco Gray (powder)  
47 = Raven Black (powder)

# NEWTON VERTICAL CABLE MANAGEMENT - SINGLE SIDED

**Customer Premise Single-Sided Vertical Cabling Section**

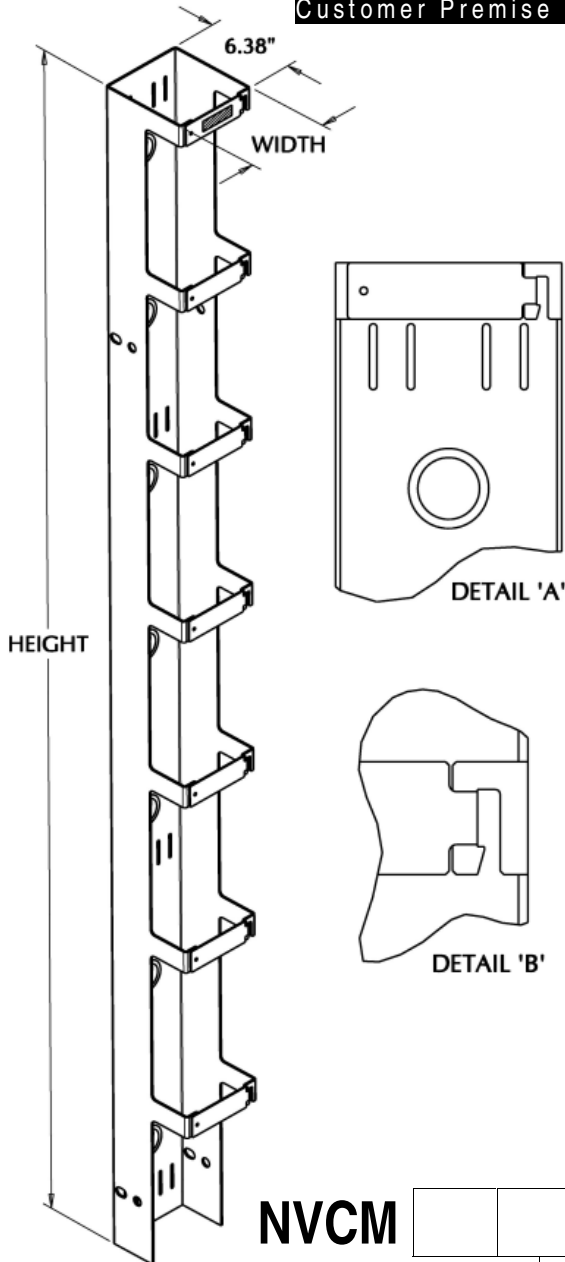

Newton Vertical Cable Management (NVCM) systems offer space-saving, high quality, and lightweight cable management options. They are single-sided, mount between equipment racks (both Newton's and others'), and all edges are protected against possible cable wear and abrasion. Available in narrow (3.65") and wide (6.00") widths, and various heights (see ordering chart below).

**Features:**

- Sturdy, lightweight aluminum construction
- Four sets of vertical slots for use with cable / zip ties for organized, bundled cables (see **Detail 'A'**)
- Seven cable and wiring pass-through holes (1 5/8" diameter) with edge protection (see **Detail 'A'**)
- Positive-locking rotating latches every 12" (see **Detail 'B'**)
- Plastic grommeting provided on all edges ensures cables and wires are protected (on unfinished units only)
- Approximate weight of 84" (7'-0") unit is 15 pounds
- Mounting hardware included with every unit
  - Additional mounting hardware available by ordering part number 2131720110
- Various heights, widths, and finishes available (see ordering chart below)

**NVCM**

--	--	--

--	--	--

--	--

**Height:**

084 = 84" / 7' overall height  
096 = 96" / 8' overall height

**Finish:**

23 = Brushed Aluminum  
30 = Telco Gray (powder)  
47 = Raven Black (powder)

**Width:**

361 = outside width dimension of 3.65"  
601 = outside width dimension of 6.00"