

HELICAL SPRING LOCK WASHER

Modified:01/23/2017

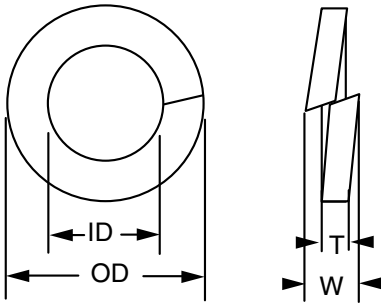

Notes:

- Finish is zinc plated and gold chromate.
- Dimensions are nominal.

	part number	size	ID	OD	W	T
Ordering Table	0030150110	no. 8	.168	.296	.055	.040
	0030150210	no. 10	.194	.337	.062	.047
	0030150310	no. 12	.221	.380	.070	.056
	0030150410	1/4"	.225	.493	.109	.062
	0030150510	5/16"	.319	.591	.125	.087
	0030150610	3/8"	.382	.688	.141	.094
	0030150710	1/2"	.509	.879	.171	.125
	0030150810	5/8"	.636	1.086	.203	.156