

**EQUIPMENT SHELF**

Modified:02/15/2012

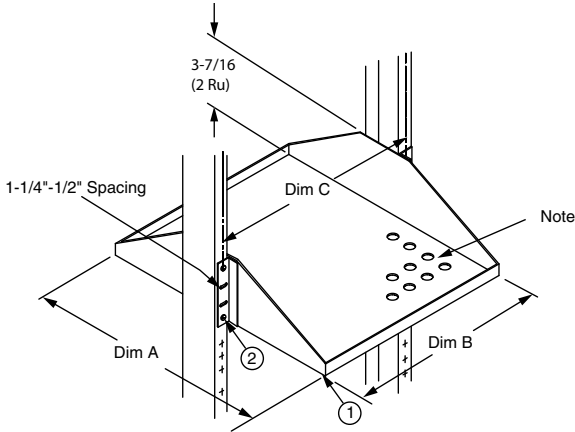

Stock List		
Item	Qty.	Description
1	1	shelf assembly
2	2	12-24 x 3/4" phms

**Notes:**

- XX = finish code; standard finish, xx = 30.
- Hole pattern is representative of entire shelf.
- Other shelf sizes available upon request.
- Steel

Ordering Table	Part Number	Rack Size	Dim A	Dim B	Dim C	Vent Hole
	00406201xx	19	11-1/2"	17-1/4"	18-5/16"	none
	00406202xx	19	13-1/2"	17-1/4"	18-5/16"	none
	00406203xx	19	15-1/2"	17-1/4"	18-5/16"	none
	00406204xx	19	19-1/2"	17-1/4"	18-5/16"	none
	00406205xx	23	11-1/2"	21-1/4"	22-5/16"	none
	00406206xx	23	13-1/2"	21-1/4"	22-5/16"	none
	00406207xx	23	15-1/2"	21-1/4"	22-5/16"	none
	00406208xx	23	19-1/2"	21-1/4"	22-5/16"	none
	00406209xx	27	11-1/2"	26	27-1/16"	none
	00406210xx	27	13-1/2"	26	27-1/16"	none
	00406211xx	27	15-1/2"	26	27-1/16"	none
	00406212xx	27	19-1/2"	26	27-1/16"	none
	21057001xx	19	24	17-1/4"	18-5/16"	none
	20340808xx	19	27	17-1/4"	18-5/16"	none
20340809xx	19	24-1/2"	17-1/4"	18-5/16"	none	
20340807xx	19	19-1/2"	17-1/4"	18-5/16"	1/4"	
20260306xx	23	22	21-1/4"	22-5/16"	none	