

UNEQUAL FLANGE EQUIPMENT RACK EXTENSION, OPEN OR CLOSED

Modified:12/27/2011

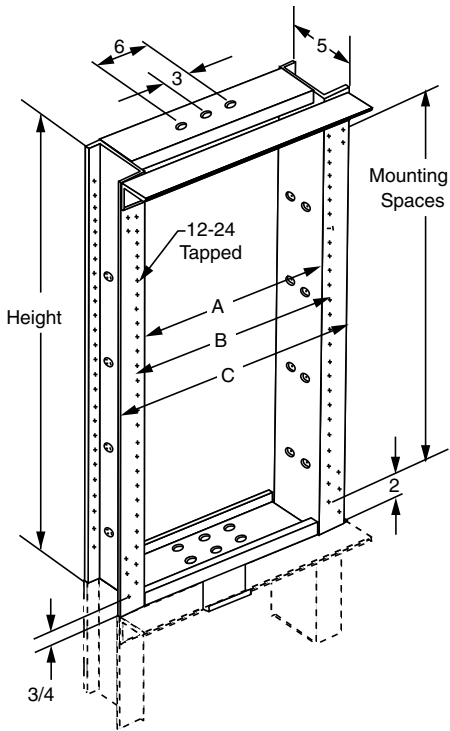

Part Number	Description	Height	Mtg Spc	A	B	C	Hole Spc
00411301 XX	7'-0" to 8'-0"	12"	7	17-1/2"	18-5/16"	21-15/16"	1"
00411302 XX	7'-0" to 9'-0"	24"	19	17-1/2"	18-5/16"	21-15/16"	1"
00411303 XX	7'-0" to 11'-6"	54"	49	17-1/2"	18-5/16"	21-15/16"	1"
00411304 XX	8'-0" to 9'-0"	12"	7	17-1/2"	18-5/16"	21-15/16"	1"
00411305 XX	8'-0" to 11'-6"	42"	37	17-1/2"	18-5/16"	21-15/16"	1"
00411306 XX	9'-0" to 11'-6"	30"	25	17-1/2"	18-5/16"	21-15/16"	1"
00411401 XX	7'-0" to 8'-0"	12"	7	21-1/2"	22-5/16"	25-15/16"	1"
00411402 XX	7'-0" to 9'-0"	24"	19	21-1/2"	22-5/16"	25-15/16"	1"
00411403 XX	7'-0" to 11'-6"	54"	49	21-1/2"	22-5/16"	25-15/16"	1"
00411404 XX	8'-0" to 9'-0"	12"	7	21-1/2"	22-5/16"	25-15/16"	1"
00411405 XX	8'-0" to 11'-6"	42"	37	21-1/2"	22-5/16"	25-15/16"	1"
00411406 XX	9'-0" to 11'-6"	30"	25	21-1/2"	22-5/16"	25-15/16"	1"
00411501 XX	7'-0" to 8'-0"	12"	4	17-1/2"	18-5/16"	21-15/16"	1-3/4"
00411502 XX	7'-0" to 9'-0"	24"	11	17-1/2"	18-5/16"	21-15/16"	1-3/4"
00411503 XX	7'-0" to 11'-6"	54"	28	17-1/2"	18-5/16"	21-15/16"	1-3/4"
00411504 XX	8'-0" to 9'-0"	12"	4	17-1/2"	18-5/16"	21-15/16"	1-3/4"
00411505 XX	8'-0" to 11'-6"	42"	21	17-1/2"	18-5/16"	21-15/16"	1-3/4"
00411506 XX	9'-0" to 11'-6"	30"	15	17-1/2"	18-5/16"	21-15/16"	1-3/4"
00411601 XX	7'-0" to 8'-0"	12"	4	21-1/2"	22-5/16"	25-15/16"	1-3/4"
00411602 XX	7'-0" to 9'-0"	24"	11	21-1/2"	22-5/16"	25-15/16"	1-3/4"
00411603 XX	7'-0" to 11'-6"	54"	28	21-1/2"	22-5/16"	25-15/16"	1-3/4"
00411604 XX	8'-0" to 9'-0"	12"	4	21-1/2"	22-5/16"	25-15/16"	1-3/4"
00411605 XX	8'-0" to 11'-6"	42"	21	21-1/2"	22-5/16"	25-15/16"	1-3/4"
00411606 XX	9'-0" to 11'-6"	30"	15	21-1/2"	22-5/16"	25-15/16"	1-3/4"

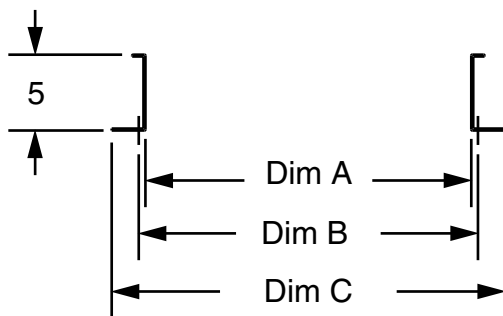

Notes:

- XX= finish code; standard finish, XX= 31.
- Closed duct rack is shown in illustration. The extension can be turned 180 degrees and mounted to open duct rack.
- Extension is designed to mount to either 3" or 5" top channel.
- Front and rear of rack extension tapped for 12-24 screws.
- Cable tie mounts are included; separately order cable tie bar kit (004119) as required. Cable ties (nylon, plastic, etc.) To be customer provided.
- Mounting hardware for attaching extension to equipment rack is provided.