

■ MOLDED POLYESTER-FIBERGLASS INSULATOR

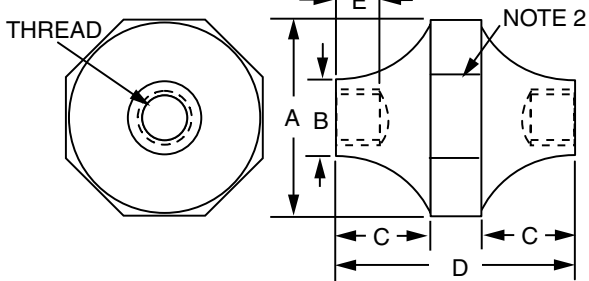

	part number	A	B	C	D	E	thread size
Ordering Table	0030610100	2"	1-1/4"	11/16"	1-1/2"	1/4"	1/4-20"
	0030610200	2"	1-1/4"	11/16"	1-1/2"	3/8"	3/8-16"
	0030610300	2"	1-1/4"	11/16"	1-3/4"	1/2"	1/2-13"
	0030610400	2-5/8"	1-1/2"	1-1/4"	2-3/4"	5/8"	5/8-11"
	0030610500	2-1/2"	1-3/8"	1-1/8"	2-5/8"	3/4"	5/8-11"
	2057750600	2"	1-1/8"	5/8"	2-1/4"	5/8"	1/2-13"

Notes:

- Insulator shape may vary from that shown dimensions are nominal, and may vary depending on shape.
- The shoulder may be round or octagonal.

■ MOLDED POLYESTER-FIBERGLASS INSULATOR

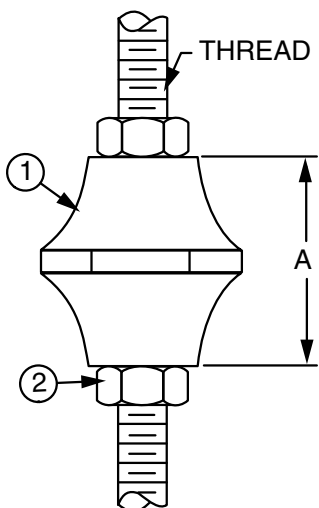

	part number	A	thread size
Ordering Table	0030630110	1-1/2"	1/4-20"
	0030630210	1-1/2"	3/8-16"
	0030630310	1-3/4"	1/2-13"
	0030630410	2-3/4"	5/8-11"

	Item	Qty	Description
Stock List	1	1	insulator
	2	2	hex nut

Notes:

- Insulator shape may vary from that shown.

■ INSULATOR, FIBERGLASS

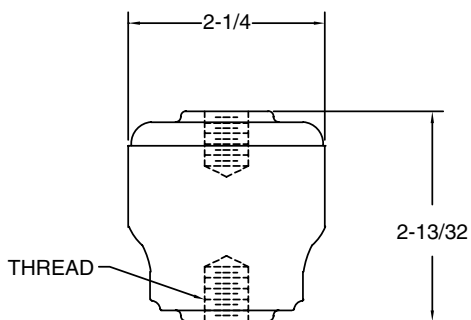

	part number	thread size
Ordering Table	2106830100	1/2-13"
	2106830200	5/8-11"

Notes:

- Material is rated ul 94 v-1 and has an oxygen index rating of greater than 29.