

DOUBLE SPACER KIT WITH D-RINGS, 2.5"

Sales Sheet Modified: 11/17/2016

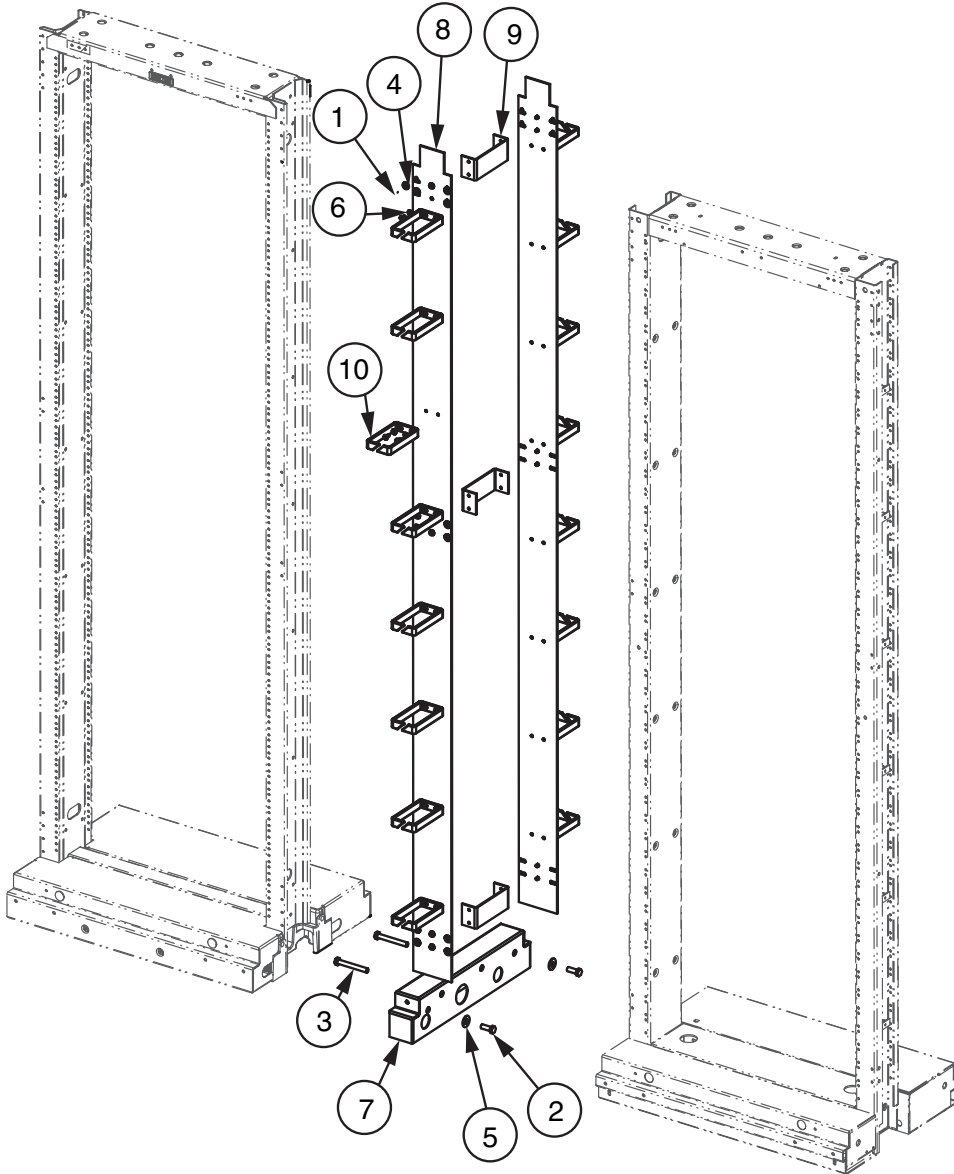

Ordering Table

Part Number

22430700xx

Stock List

Item	QTY	Description
1	56	12-24 x 3/8" PHMS
2	4	3/8-16 x 1" HHCS
3	4	3/8-16 x 3" HHCS
4	12	#12 Flat Washer
5	4	3/8" Flat Washer
6	44	#12 External Tooth Washer
7	1	Spacer Box 2.5" x 18"
8	2	D-Ring spacer Panel
9	3	"C" bracket
10	16	D-Ring